



## *List of Patents*



*Mass Manufacturer  
of Secure and Clean Power*

***LIST OF PATENTS***

**WO 2004052774 A2      PRODUCTION OF HYDROGEN FROM SILICON**

**Abstract** - Hydrogen is produced by reacting amorphous silicon with water, an alcohol or a carboxylic acid at room temp. The formed byproducts, e.g.  $\text{SiO}_2$  and  $\text{Si(OR)}_4$  with R being an alkyl or carbonic acid group, can be recycled or used for other applications.

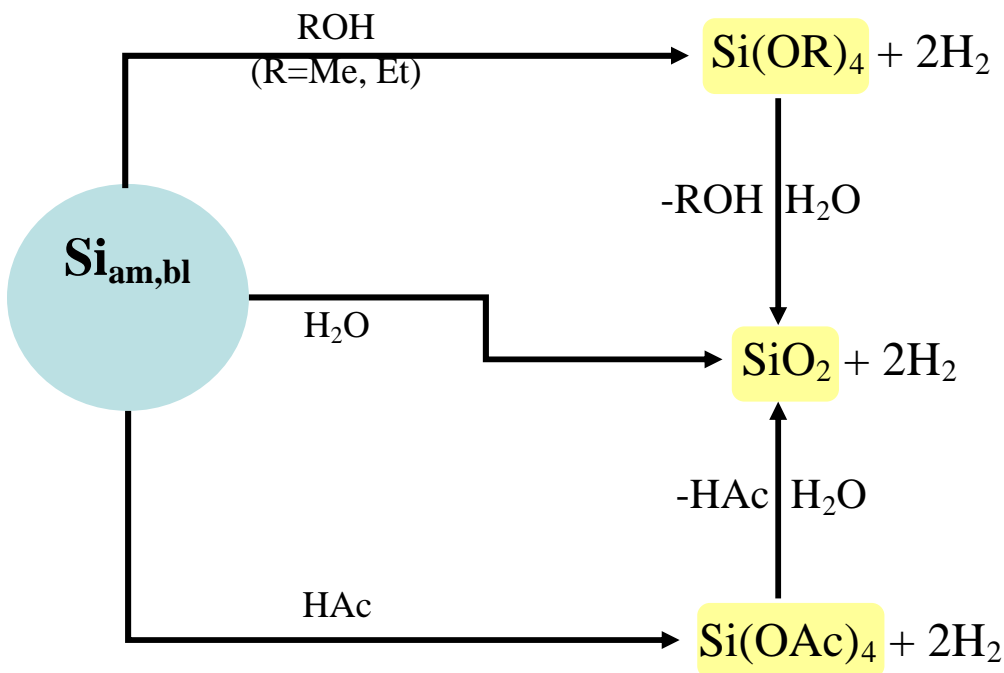

**WO 2003059815 A1      PRODUCTION OF AMORPHOUS SILICON AND/OR ORGANOHALOSILANES**

**Abstract** - The invention relates to a method for producing amorphous Si and/or organohalosilanes. In a 1st embodiment of the method, a halosilane is reacted with a metal in a non-polar solvent. In a 2nd embodiment, the black amorphous Si is reacted



**Abstract** - Energy is produced in following steps (1) recovery of Si from SiO<sub>2</sub> and/or silicates especially fluorosilicates, and (2) treatment of the recovered Si with H<sub>2</sub>O (especially seawater) to high-purity SiO<sub>2</sub> under release of energy and H<sub>2</sub>. The recovery of Si from SiO<sub>2</sub> and/or silicates results by treatment of the SiO<sub>2</sub> and/or silicates with HF to SiF<sub>4</sub> which can be treated thermolytically, catalytically, or by reduction with metals or metal hydrides to Si.

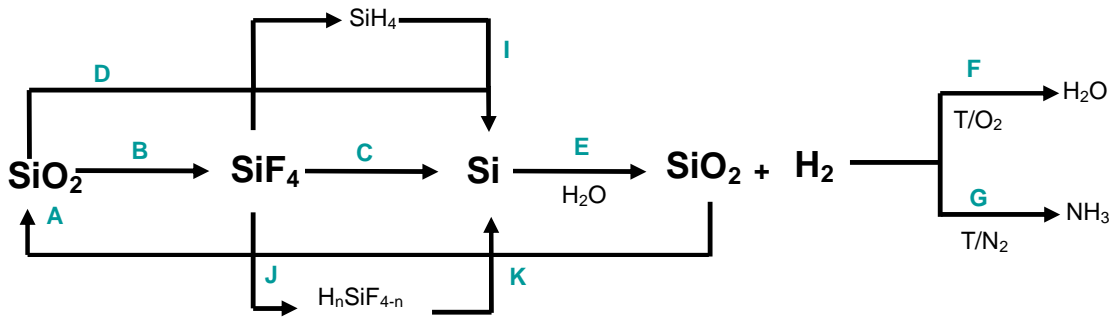

**WO 2002090254 A1**

**PROCEDURE FOR THE PRODUCTION OF SILICON NITRIDE BY TREATMENT OF A SILICON-CONTAINING MIXTURE OR ALLOY WITH AIR**

**Abstract** - Si<sub>3</sub>N<sub>4</sub> is produced in the following steps (1) manufacturing of a mixture or an alloy containing Si and a chemical element or compound reacting with O<sub>2</sub> faster or just as fast as Si, (2) heating up the mixture or alloy at an ignition point of the element or compound followed by charging with air, (3) oxidation of the element or compound with O<sub>2</sub> from air, and (4) combustion of Si with the residual N<sub>2</sub> from air at an increased temperature generating by the oxidation step 3.

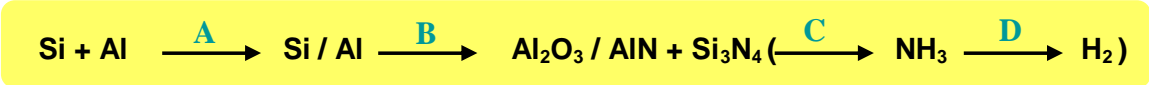

**WO 2002090255 A1**

**PROCEDURE FOR THE ENERGY PRODUCTION BY MANUFACTURE OF ALUMINUM NITRIDE AND ITS REACTION WITH WATER TO ALUMINUM OXIDE AND AMMONIA**

**Abstract** - Energy is produced by manufacturing of AlN from Al and N<sub>2</sub> or by reaction of the manufacturing AlN with H<sub>2</sub>O to Al<sub>2</sub>O<sub>3</sub> and NH<sub>3</sub>. The produced thermal energy is transformed to kinetic energy for operating turbines. Al<sub>2</sub>O<sub>3</sub> can be used for the

manufacturing of Al or AlN by reaction with C and N<sub>2</sub> and NH<sub>3</sub> can be used for the manufacturing of fertilizers or as H<sub>2</sub> carrier which can be combusted in fuel cells.

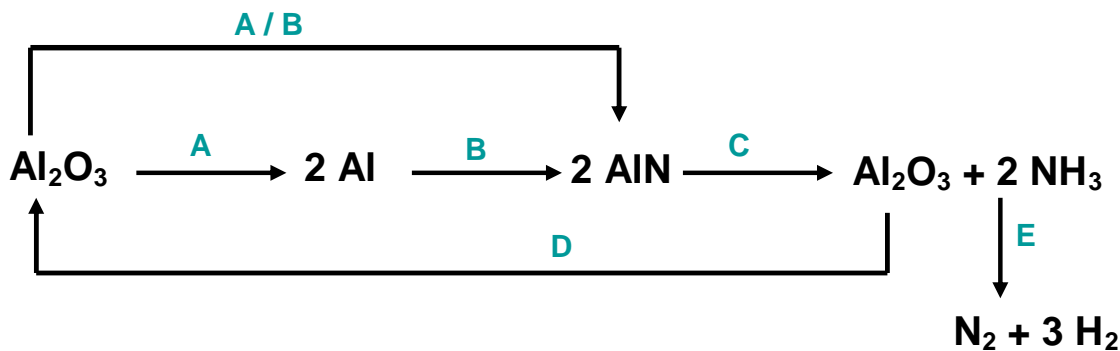

WO 2001098205 A1

**PRODUCTION OF AMMONIA BY CATALYTIC REACTION OF SILICON AND/OR SILICON COMPOUNDS WITH NITROGEN FOLLOWED BY TREATMENT OF THE RESULTING SILICON NITRIDE**

**Abstract** - NH<sub>3</sub> is manufactured by reaction of Si, and/or Si compounds especially silanes with N<sub>2</sub> in the presence of a catalyst selected from subgroup elements or subgroup element oxides. The resulting Si<sub>3</sub>N<sub>4</sub> can be further treated optionally with (1) a strong base or their aqueous solution, (2) CO<sub>2</sub> and H<sub>2</sub>O followed by thermal decomposition or treatment with a strong base of the resulting (NH<sub>4</sub>)<sub>2</sub>CO<sub>3</sub>, or with (3) HF to give NH<sub>3</sub>.

**Reaction 1**



$$\Delta H = -295 \text{ kJ/mol Me}_2\text{SiCl}_2$$

$$\text{onset temperature} = 147 \text{ }^\circ\text{C}$$

$$\text{Si/CuO} \Rightarrow 103 \text{ }^\circ\text{C}$$

**Reaction 2**

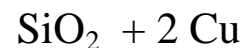

$$\Delta H = -300 \text{ kJ/mol CuO}$$

$$\text{onset temperature} = 370 \text{ }^\circ\text{C}$$

$$\text{Si/CuO} \Rightarrow 190 \text{ }^\circ\text{C}$$

**Reaction 3**

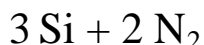

$$\Delta H = -750 \text{ kJ/mol Si}_3\text{N}_4$$

$$\text{onset temperature} = 1000 \text{ }^\circ\text{C}$$

$$\text{Si/CuO} \Rightarrow 740 \text{ }^\circ\text{C}$$

**WO 9802393 A1****COMPOSITIONS FOR FIRE-RESISTANT FOAM AND INSULATION**

**Abstract** - The compositions, containing a 20-70-wt.% aqueous  $\text{Al}(\text{H}_2\text{PO}_4)_3$  solution 30-90, a mixture consisting of MgO 10-70, mica 0-70,  $\text{Al}(\text{OH})_3$  0-70, and  $\text{MnO}_2$  1-20 wt.% 5-55, and a 3-33-wt.% aqueous  $\text{H}_2\text{O}_2$  solution as foaming agent 1-30 wt. parts, additionally containing □1 inorganic fillers 1-60 and □1 organic processing agents 1-60 wt.%. A composition consisting of  $\text{Al}(\text{H}_2\text{PO}_4)_3$  29, water 29, MgO 16, mica 5,  $\text{Al}(\text{OH})_3$  5  $\text{MnO}_2$  5, filler 12,  $\text{H}_3\text{BO}_3$  1, grog 7, clay 4,  $\text{H}_2\text{O}_2$  0.72, and water 3.28 wt. parts.

**EP 752396 A1****FOAMED INORGANIC MATERIAL AND THEIR MANUFACTURE**

**Abstract** - The materials consist of a 20-70-wt.% aqueous  $\text{Al}(\text{H}_2\text{PO}_4)_3$  solution 40-90, a mixture containing MgO 10-70, mica 10-70,  $\text{Al}(\text{OH})_3$  10-70, and  $\text{MnO}_2$  2-20 wt.% 5-55, and foaming agent containing a 3-33-wt.% aqueous  $\text{H}_2\text{O}_2$  solution 1-30 wt. parts. The materials are manufactured by dispersing the mixture under agitation in the  $\text{Al}(\text{H}_2\text{PO}_4)_3$  solution and adding the foaming agent, casting the dispersion into a mold, allowing 0.5 - 10 min for foaming, and cooling the foamed material. A mixture consisting of MgO (purity >95%) 20, mica (particle size 60 mesh) 30,  $\text{Al}(\text{OH})_3$  ( $\text{Al}_2\text{O}_3$  content 65%) 50, and  $\text{MnO}_2$  (particle size <100 □m) 10 was dispersed in a 50-wt.% aqueous  $\text{Al}(\text{H}_2\text{PO}_4)_3$  solution 100 under agitation for 60 s, after which 18% aqueous  $\text{H}_2\text{O}_2$  solution was added. The mixture foamed for 1 min to 400-500% of its original volume. The foamed material was stored on the air for 3 days to give cellular material having a density of  $0.22 \text{ g/cm}^3$ , compressive strength  $21 \text{ N/cm}^2$ . The material showed a compression of 12% under a load of  $11,000 \text{ N/cm}^2$ .

**DE 29803325.9****FUEL CELL WITH SOLID ELECTROLYTE AND PLANAR STRUCTURE**

**Abstract** - The invention relates to a fuel cell (1), comprising at least two electrodes (4, 8) arranged in a housing (2, 3, 15), a solid electrolyte (6) positioned between said electrodes (4, 8), at least one hydrogen inlet connection (16, 17) at the level of at least one first electrode (4) and at least one oxygen supply point (20) at the level of at least one second electrode (8). To produce said fuel cell the housing is assembled from two outer housing plates (2, 3) the first (2) of which is fitted with the at least one hydrogen inlet connection (17) and the second (3) of which with the at least one oxygen supply point (20). The two electrodes (4, 8) and the solid electrolyte are arranged between the two outer housing

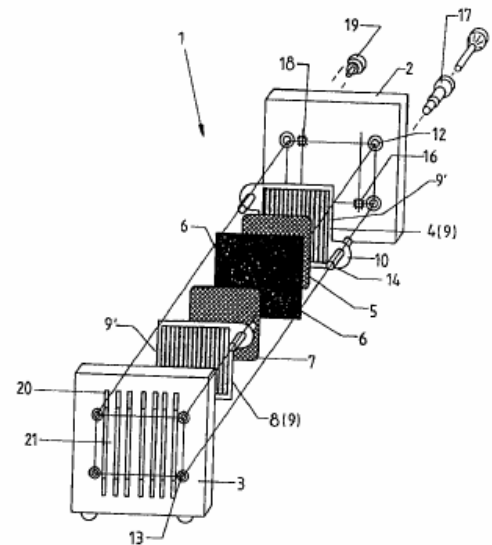

plates (2, 3) in the formed of plate-like elements. A gap between the housing plates (2, 3) can be filled with a cast plastic material which forms a frame which seals the inner s pace of the fuel cell in a gas-proof manner.

**DE 29811922.6 FUEL CELL AND FUEL CELL ARRANGEMENT**

**Abstract** - The invention is a variant of the fuel cell covered by DE 29803325.9.

**DE 19916239.5 FUEL CELL WITH POLYMER ELECTROLYTE**

**Abstract** - The Invention is the same as in DE 50001395.0.

**DE 50001395.0 FUEL CELL WITH POLYMER ELECTROLYTE**

**Abstract** - A fuel cell (1) is provided with a central polymer membrane (2) that is provided with diffusion layers (3, 4) covering both sides and having plane electrodes (5, 6) supporting the back surface of said layers. The electrodes (5, 6) are provided with openings (15, 16) and rear covers (7, 8) with gas supplies (9, 10) for at least one of the plane electrodes (5, 6). At least two parallel extending gas flow channels (11, 12; 13, 14) sealed against each other are configured between at least one plane electrode (5, 6) and the cover (7, 8) pertaining thereto. Openings (15) in the plane electrode (6) extend from one gas flow channel (13) into the adjacent diffusion layer (4) and from the diffusion layer (4) into the other gas flow channel (14). The fuel cell (1) is provided with a greater dimension lengthwise in the main extension direction of the gas flow channels (11, 13) than vertical thereto.

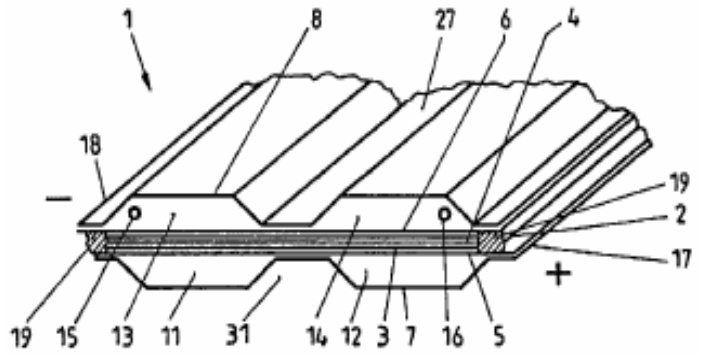

**DE 19916240.9 HYDROLYZER**

**Abstract** - A hydrolyzer has a central polymer membrane with a diffuser layer on both sides, supported on the back by perforated flat electrodes, water reservoir(s), supplying water through one of the diffuser layers to the

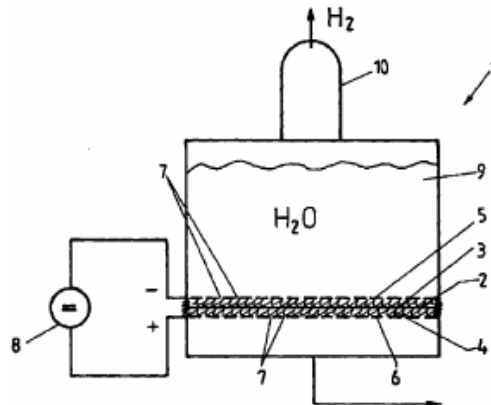

Fig. 1

membrane, and a voltage supply for applying voltage between the electrodes to produce a potential difference. The novelty is that the water reservoir(s) is on the same side of the membrane as the electrode at the lower potential.

**DE 19916243.3**

**DEVICE FOR CONVERTING ENERGY WITH AT LEAST ONE FUEL CELL AND/OR ONE HYDROLYSER**

**Abstract** - An energy conversion equipment (1) comprises fuel cell electrodes (7) which can be short-circuited by a conductive rotor casing (16) of a unipolar machine (3). An Independent claim is also included for energy conversion apparatus in which the fuel cell (2) of the above equipment is replaced by a hydrolyzer.

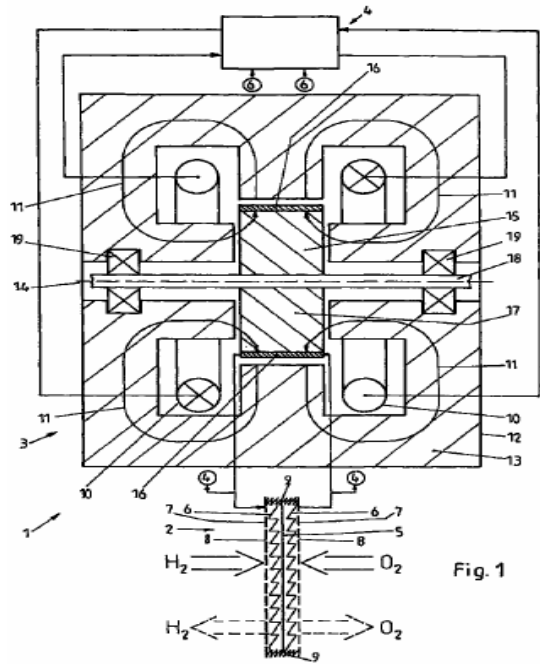
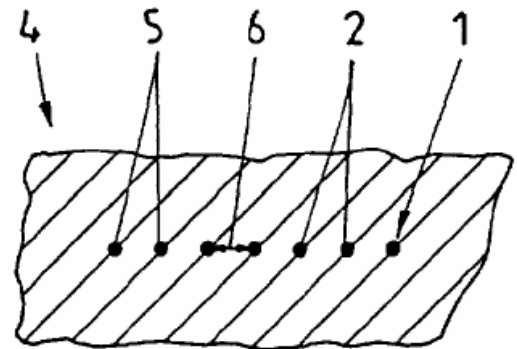

Fig. 1

**DE 10013900.0**

**FUEL CELL WITH PERFORATED PLANAR ELECTRODE ADJACENT TO ION EXCHANGE LAYER, HAS FILLED PERFORATIONS WHERE ELECTRODE IS LED OUT THROUGH SEALANT MASS**

**Abstract** - The planar electrode (17) is led out through the sealant mass (7). The sealant fills electrode perforations (18) in this region, completely embedding the electrode.





DE 10131359.4

**PRODUCTION OF A FLAT ELECTRODE COATED WITH PLATINUM AND/OR PALLADIUM ON ONE SIDE USED E.G. FOR A FUEL CELL COMPRISES PRODUCING A THIN LAYER OF PLATINUM AND/OR PALLADIUM, AND APPLYING ON THE BASE STRUCTURE OF THE FLAT ELECTRODE**

**Abstract** - Production of a flat electrode coated with platinum and/or palladium on one side comprises producing a thin layer (4) of platinum and/or palladium, and applying on the base structure (16) of the flat electrode. An Independent claim is also included for the flat electrode produced. Preferred Features: Gold can be added to the layer before the layer is applied on the base structure of the electrode. The platinum or palladium has a thickness of less than  $1 \times 10^{-6}$  m. The layer is applied to the electrode using water to which gelatin is added. The base structure is made from titanium or graphite.

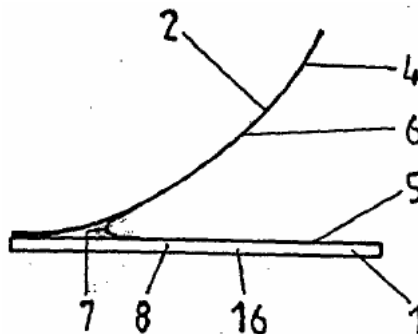

DE 10201149.4

**ELONGATED FUEL CELL WITH TRANSVERSE CHANNELS FOR GAS SUPPLY HAS SEVERAL OF THE TRANSVERSE CHANNELS WITH CROSS-SECTION DECREASIN FROM ONE LONGITUDINAL EDGE OF FUEL CELL TO THE OTHER**

**Abstract** - The invention is the same as in EP 03000354.5.

DE 10163687.3

**FUEL CELL OR HYDROLYZER COMPRISES A CENTRAL PROTON EXCHANGE MEMBRANE, A DIFFUSER LAYER ON ONE SIDE OF THE MEMBRANE, AND A FLAT ELECTRODE HAVING OPENINGS AND SUPPORTING THE DIFFUSER LAYER**

**Abstract** - Fuel cell or hydrolyzer comprises a central proton exchange membrane, a diffuser layer on one side of the membrane, and a flat electrode (6) having openings and supporting the diffuser layer. The flat electrode has a base structure (8) containing at least 90 wt.% nickel and having a precious metal coating (9).

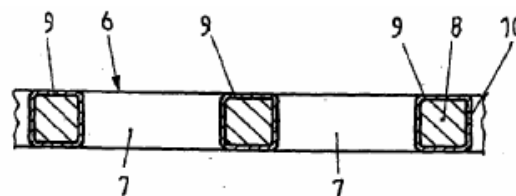

The precious metal coating completely covers the base structure in the fuel cell or hydrolyzer and contains at least 99% platinum and/or palladium. Preferred Features: The base structure contains at least 96, preferably 99 wt.% nickel. The base structure is produced using a mask. A phosphorus-nickel layer is provided between the base structure and the precious metal coating.

**DE 10200222.3**

**FUEL CELL WITH AN INTERNAL CHAMBER, IN WHICH A GAS STORAGE DEVICE IS PLACED**

**Abstract** - The fuel cell (1) has an inner space (11) defined by a tubular body (2) containing a gas reservoir (12), the tubular body having a layer structure (3) with a central proton exchange membrane (5) sandwiched between diffuser layers. The gas reservoir supplies the inner diffuser layer with a reaction gas, one end of the tubular body closed by an elastically-deformable membrane (16), provided with an operating element for the discharge valve for the pressure reservoir, e.g. a metal hydride reservoir for hydrogen.

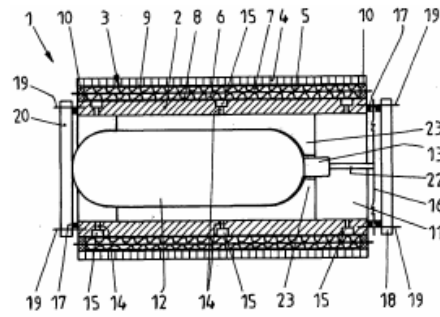

Fig. 1

**DE 10201145.1**

**FUEL CELL OR HYDROLYSER AND METHOD FOR PRODUCING A FUEL CELL OR A HYDROLYSER**

**Abstract** - The invention is the same as in EP 03000353.7.

**DE 10201148.6**

**METHOD AND APPARATUS FOR APPLYING A PRESSURE FORCE TO SHEET ELECTRODES OF A FUEL CELL OR OF A HYDROLYSER**

**Abstract** - The invention is the same as in EP 03000352.9.

**DE 10200404.8**

**AIR-HEATING DEVICE WITH FUEL CELL**

**Abstract** - The invention is the same as in EP 03000250. 5.

DE 19526609.9

### TUBULAR ASSEMBLY OF ELECTRODES AND MEMBRANE FORMING FUEL CELL

**Abstract** - Two electrodes (2,4) and an intermediate ion exchange membrane (3) form a fuel cell of tubular form. The H<sub>2</sub> electrode (2) is the innermost electrode and is surrounded by the membrane and then the O<sub>2</sub> electrode. The H<sub>2</sub> electrode forms a central H<sub>2</sub> inlet (1) and a gas-permeable protective sheath (5) can be provided on the outside of the assembly. O<sub>2</sub> e.g. from the air passes to the O<sub>2</sub> electrode through the sheath.

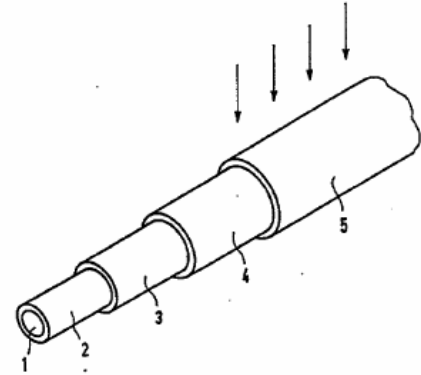

EP 00107637.1;

### HYDROLYZER

**Abstract** - The invention is the same as in DE 19916240.9.

EP 01125682.3

### PRESSURE DIFFERENCE SAFETY VALVE

**Abstract** - The invention is the same as in DE 10053609.3.

EP 02029001.1

### FUEL CELL WITH AN INTERNAL CHAMBER, IN WHICH A GAS STORAGE DEVICE IS PLACED

**Abstract** - The invention is the same as in DE 10200222.3.

EP 03000354.5

### ELONGATED FUEL CELL HAVING CROSS CHANNELS FOR GAS SUPPLY

**Abstract** - The device has transverse channels (6) for gas supply on at least one side of a polymer electrolyte membrane or PEM (2). The channels are formed behind a diffusion layer covering the PEM near an electrode surface supporting the diffusion layer and run transversely to the fuel cell's longitudinal edges (10). Several of the transverse channels have a cross-section decreasing from one longitudinal edge of the fuel cell to the other.

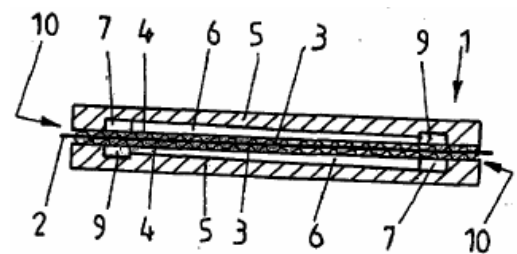

EP 03000353.7

### FUEL CELL OR HYDROLYSER AND METHOD FOR PRODUCING A FUEL CELL OR A HYDROLYSER

**Abstract** - The fuel cell or hydrolyzer has a central proton exchange membrane (2), diffuser layers (3) covering the membrane and flat electrodes (4) contacting the diffuser layers at the rear, of which at least one is supported on a rear cover via a seal (5). The seal has a volume expanded and/or volume expandable component activated by a chemical and/or physical effect. AN Independent claim is also included for the following: a method of manufacturing an inventive device.

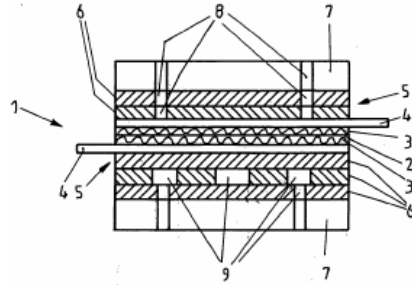

Fig. 1

EP 03000352.9

### METHOD AND APPARATUS FOR APPLYING A PRESSURE FORCE TO SHEET ELECTRODES OF A FUEL CELL OR OF A HYDROLYSER

**Abstract** - The fuel cell (1) or hydrolyzer has a layered structure (2) with a central proton exchange membrane (5), diffuser layers covering the membrane and flat electrodes supporting the rear of the diffuser layers. The layer structure is mounted on a core (3). The method involves increasing the diameter of the core by subjecting it to hydraulic or pneumatic pressure. AN Independent claim is also included for the following: a fuel cell or hydrolyzer.

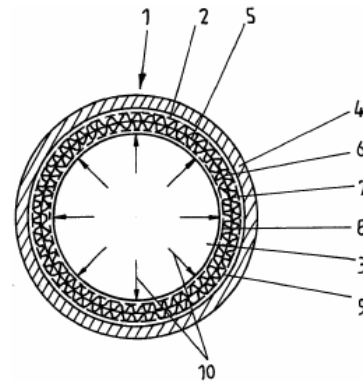

Fig. 1

EP 03000250.5

### AIR-HEATING DEVICE WITH FUEL CELL

**Abstract** - The device has an air supply (11) and at least one air-breathing fuel cell (3) for oxidation of a fuel gas. The fuel cell has a proton exchange membrane for cold oxidation of the gas. The air supply runs past the fuel cell to supply the cell with oxygen and to simultaneously heat the air with the waste heat from the fuel cell.

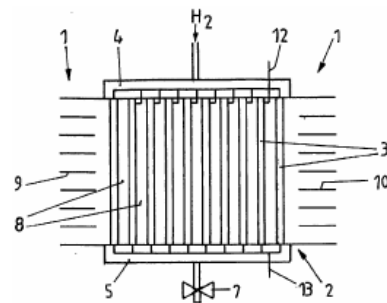

Fig. 1